

OR-VID-EX-1057KV

VIDEO CAMERA

ORNO-LOGISTIC Sp. z o.o.
ul. Rolników 437,
44-141, Gliwice POLAND
tel. (+48) 32 43 43 110

SAFETY NOTES

(EN) IMPORTANT!

Before using the device, read this Service Manual and keep it for future use. Any repair or modification carried out by yourselves results in loss of guarantee. Mounting should be performed by an appropriately qualified person. The manufacturer is not responsible for any damage that can result from improper device installation or operation.

In view of the fact that the technical data are subject to continuous modifications, the manufacturer reserves a right to make changes to the product characteristics and to introduce different constructional solutions without deterioration of the product parameters or functional quality. The latest version of the Manual can be downloaded from suport.orno.pl. Any translation/interpretation rights and copyright are reserved in relation to this Manual.

1. Do not use the device contrary to its dedication.
2. Disconnect the power supply before any activities on the product.
3. Do not immerse the device in water or other fluids.
4. Do not operate the device when its housing is damaged.
5. Do not open the device and do not repair it by yourselves.



Each household is a user of electrical and electronic equipment, and hence a potential producer of hazardous waste for humans and the environment, due to the presence of hazardous substances, mixtures and components in the equipment. On the other hand, used equipment is valuable material from which we can recover raw materials such as copper, tin, glass, iron and others. The weee sign placed on the equipment, packaging or documents attached to it indicates the need for selective collection of waste electrical and electronic equipment. Products so marked, under penalty of fine, cannot be thrown into ordinary garbage along with other waste. The marking means at the same time that the equipment was placed on the market after August 13, 2005. It is the responsibility of the user to hand the used equipment to a designated collection point for proper processing. Used equipment can also be handed over to the seller, if one buys a new product in an amount not greater than the new purchased equipment of the same type. Information on the available collection system of waste electrical equipment can be found in the information desk of the store and in the municipal office or district office. Proper handling of used equipment prevents negative consequences for the environment and human health!

09/2021

TECHNICAL DATA

Power consumption:	3W
Viewing angle:	110° (horizontal), 96° (vertical)
Camera resolution:	700TVL
Video:	1Vp-p 75 Ohm Ω (output)
Audio:	300mVp-p 300 Ohm Ω (bi-directional)
Backlighting:	white LED
Minimum light intensity:	0 LUX (0.5 m)
Ingress protection:	IP 65
Working temperature:	-25°C +60°C
Material:	aluminium
Dimensions:	55 x 152 x 21 mm
Net weight:	0.29 kg

DESCRIPTION AND FUNCTIONS

Single-family video camera, 1 call button, high-quality wide-angle lens, colour camera 700TVL, weather-proof, surface-mounted, super-bright LEDs for night vision, possibility of conversation between the external panel (video camera) and internal panel, illuminated name space, gate control option.

CONSTRUCTION

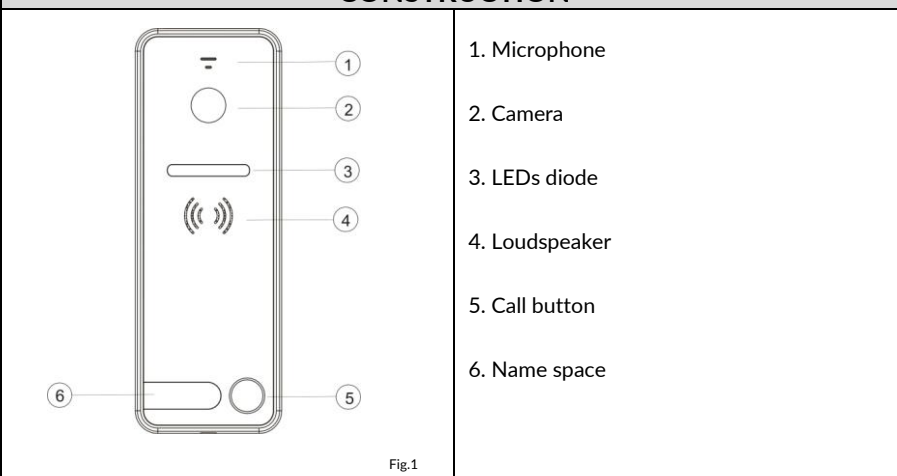

1. Microphone
2. Camera
3. LEDs diode
4. Loudspeaker
5. Call button
6. Name space



WIRING DIAGRAM

Wire no.	COLOR		SIGNAL	
	Front	Back	Front	Back
1	RED	RD	AUDIO1	AD1
2	BLUE	BU	GROUND1	GND1
3	YELLOW	YL	POWER1	PWR1
4	WHITE	WT	VIDEO1	VD1
5	BLUE-BLACK	BU-BK	GROUND2	GND2
6	YELLOW-BLACK	YL-BK	POWER_LOCK	PWR_LOCK
7	WHITE-BLACK	WT-BK	NORMALLY OPEN_2	NO_2
8	BLACK	BK	COMMON_1	COM_1
9	BROWN	BN	NORMALLY OPEN_1	NO_1

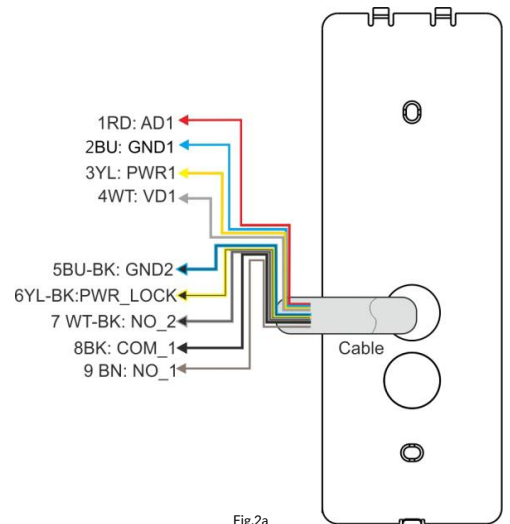

Fig.2a

Scheme of connection of an electric door strike supplied with a separate 12VDC power

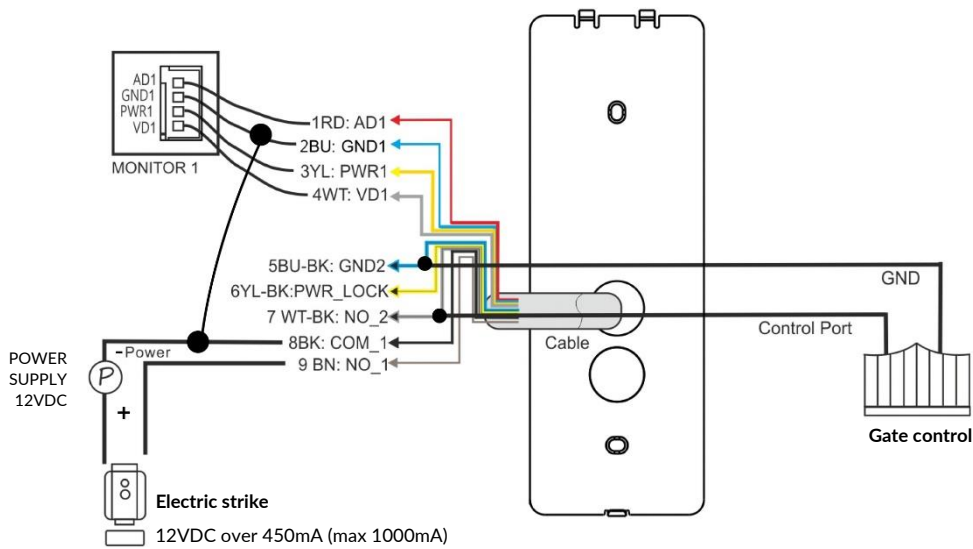

Fig.2b

Connection diagram of an electric door strike powered from the video door entry system

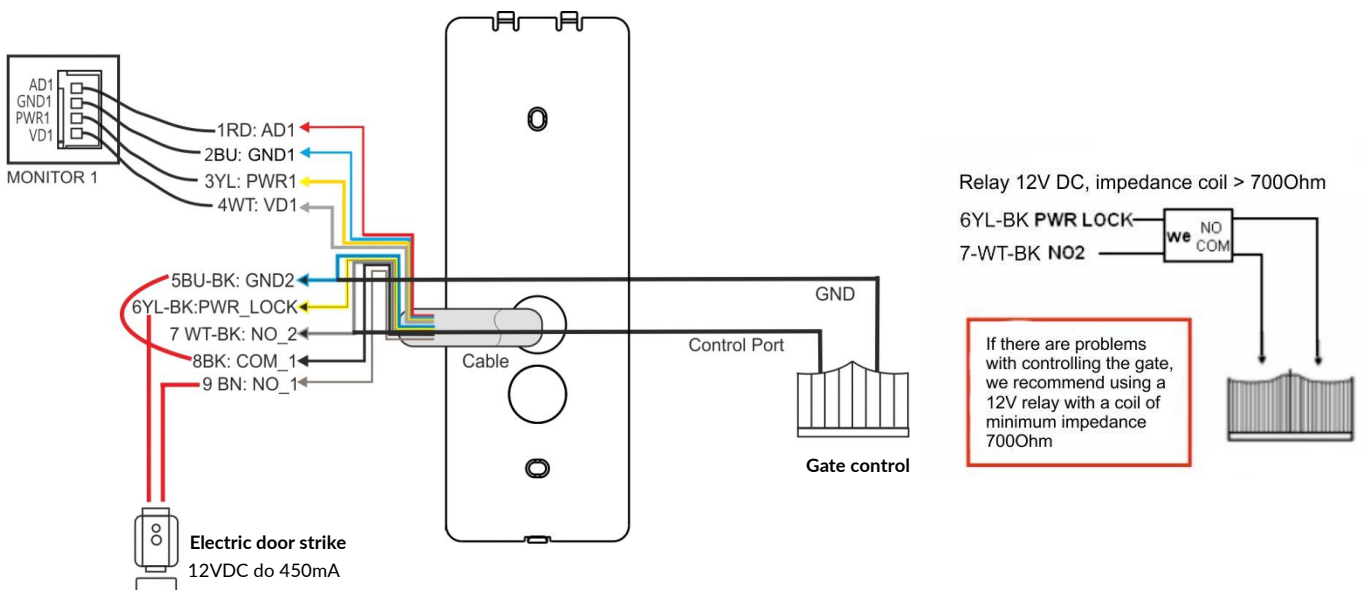

Fig.2c

Fig.2d

While designing the wiring system, take into account the suitable cross-section of cables: up to 30 m - recommended cable XzTKMXpw 3 x 2 x 0,5 mm² from 30 m to 100 m - recommended cable XzTKMXpw 3 x 2 x 0,8 mm². The connection to the electromagnetic lock should be made with 2 x 1 mm². An electric door strike with a voltage of 12VDC and a current of up to 450mA (not supplied) works properly with the external panel. In case of using an electric door strike with higher power consumption, it is recommended to use an electric door strike with memory.

EXTERNAL PANEL INSTALLATION

Proper placement of the external panel determines the comfort of working with the device, therefore, before making mounting holes, it is recommended to adjust the place of installation and test the operation of the device. For this purpose, connect the device according to the wiring diagram, carefully examine the field of view of the camera and test it.

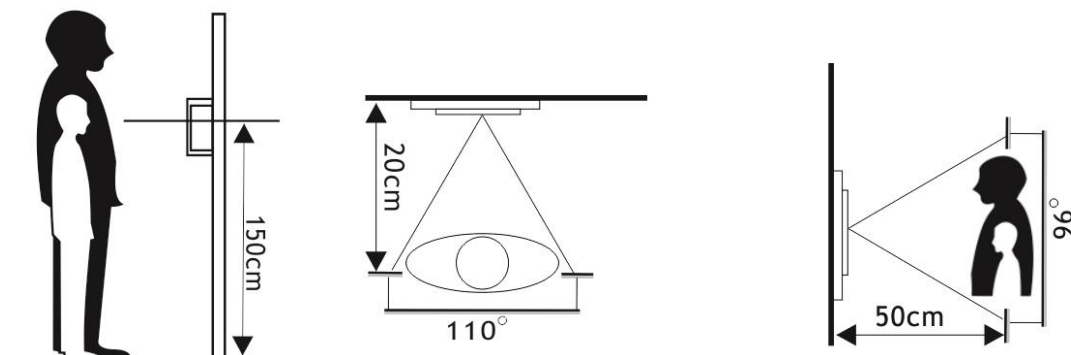

Fig.3

The outdoor panel is designed for surface mounting. Suggested placement height of the camera is 1.5 ~ 1.6 m.

Video intercom cables should not be installed in the same cable as other installations, e.g. doorbell, alarm, etc. All power and power and telecommunication cables emitting strong magnetic fields (e.g. loudspeakers, TV set) which are in direct contact with cables connecting external panel with monitor may adversely affect the set's operation.

INSTALLATION

Surface mounting

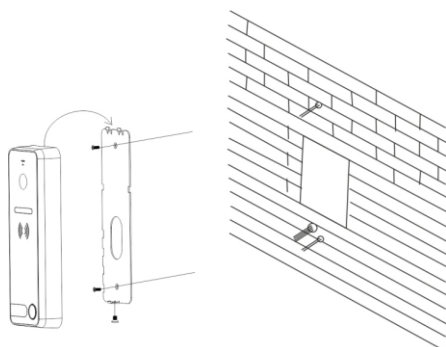

Fig.4

Angle bracket mounting

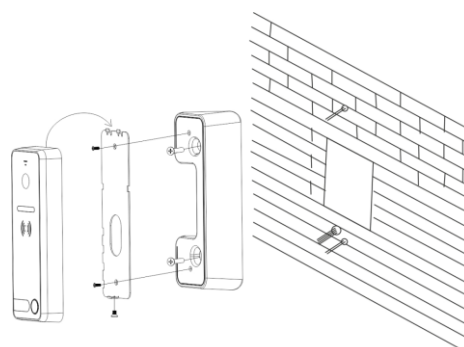

Fig.5

1. Select a mounting location for the camera and connect the appropriate cables.
2. Remove the bottom screw and separate the mounting frame from the external panel.
3. Drill holes in the wall or post for the wall plugs.
4. **Surface mounting:** Attach the mounting frame to the wall (post).
5. **Angle bracket mounting:** fix the angle bracket to the wall, then the mounting frame
6. Connect the wires to the sockets on the back of the panel according to the wiring diagram.
7. Attach the external panel to the frame.
8. Screw the bottom screw of the external panel to the frame.

SAFETY AND MAINTENANCE

Do not install the camera where the camera lens will be directly exposed to sunlight or strong lighting. If light falls directly on the lens of the outdoor camera, the image will be overexposed; white or only outlines will be visible. Do not use cleaning agents based on solvents, petrol, etc. or agents containing abrasive substances. Clean dirt only with a soft damp cloth and a small amount of detergent designed for cleaning plastic parts.