

ViRONE

Operating and installation instructions

Video doorphone set AVONI

VDP-78



STOP!

Be sure to read the instruction manual before installation!
Damage resulting from incorrect connection
ARE NOT SUBJECT TO REPAIR UNDER WARRANTY!

TABLE OF CONTENTS

1. SAFETY INSTRUCTIONS.....	3
2. CHARACTERISTICS OF THE SET	3
3. INTENDED USE.....	3
4. TECHNICAL DATA	4
5. SET CONSTRUCTION	5
6. INSTALLATION.....	6
7. WIRING DIAGRAMS	8
8. OPERATION.....	10
CALL.....	10
MAIN SCREEN.....	11
APP	12
CAMERA	12
INTERCOM.....	14
HISTORY	15
ALARM	16
9. SYSTEM SETTINGS	17
BASIC	17
SOUND	18
DISPLAY	19
DATE AND TIME.....	20
NETWORK SETTINGS	20
SYSTEM SETTINGS	21
SYSTEM SETTINGS – USER SETTINGS – MOTION DETECTION	21
SYSTEM SETTINGS – USER SETTINGS – DOOR SETTINGS.....	22
SYSTEM SETTINGS – USER SETTINGS – PASSWORD SETTINGS	22
SYSTEM SETTINGS – USER SETTINGS – ALARM SETTINGS.....	23
SYSTEM SETTINGS – USER SETTINGS – IPC MONITORING	23
SYSTEM SETTINGS – USER SETTINGS – OTHER	24
SYSTEM SETTINGS – TECHNICAL SETTINGS – DEVICE ID.....	24
SYSTEM SETTINGS – TECHNICAL SETTINGS – ALARM SETTINGS	25
SYSTEM SETTINGS – TECHNICAL SETTINGS – OTHER.....	25
15. WI-FI CONNECTION	26
16. APP USAGE	27
17. RFID CARDS.....	28
18. TROUBLESHOOTING	28
19. CLEANING AND MAINTENANCE	28
20. AFTER-SALES SERVICE	29
21. SAFETY-RELATED COMMUNICATION CHANNELS	29
22. ADDITIONAL INFORMATION.....	29

1. SAFETY INSTRUCTIONS

Warnings and precautions for the safe use of the product:







1. Before using the device, read this user manual carefully and keep it for future reference.
2. Self-repairs or modifications will void the warranty.
3. The device may only be used as intended. Any other use is considered unsafe.
4. The manufacturer is not liable for damages resulting from improper installation or use of the device.
5. The installation of the device should be performed by an experienced person with the appropriate qualifications.
6. Perform all tasks with the power supply disconnected.
7. Do not immerse the device in water or other liquids.
8. Do not operate the device if the housing is damaged.
9. Do not touch internal components of the operating device directly or indirectly – risk of electric shock and/or burns.
10. Do not cover the device. Ensure free airflow.
11. Do not install the device near sources of strong radiation, e.g. lifts and other drive systems powered by alternating current.
12. Do not install the monitor in a place exposed to high moisture, vibration, shock and strong sunlight.
13. Turn off the power if there is a concerning sound coming from the device.
14. Remove the protective film from the monitor screen after installation and mounting.
15. Avoid striking, shaking, or colliding other objects with the device, as this may cause damage to the internal components of the unit.

Disposal instructions

 Each household is a user of electrical and electronic equipment, and hence a potential producer of hazardous waste for humans and the environment, due to the presence of hazardous substances, mixtures and components in the equipment. On the other hand, used equipment is valuable material from which we can recover raw materials such as copper, tin, glass, iron and others. The WEEE sign placed on the equipment, packaging or documents attached to it indicates the need for selective collection of waste electrical and electronic equipment. Products so marked, under penalty of fine, cannot be thrown into ordinary garbage along with other waste. The marking means at the same time that the equipment was placed on the market after August 13, 2005. It is the responsibility of the user to hand the used equipment to a designated collection point for proper processing. Used equipment can also be handed over to the seller, if one buys a new product in an amount not greater than the new purchased equipment of the same type. Information on the available collection system of waste electrical equipment can be found in the information desk of the store and in the municipal office or district office. Proper handling of used equipment prevents negative consequences for the environment and human health!

11/2025

Applied markings

1.	2.	3.
		
		

1. Product compliant with EU directives.
2. Manufacturer.
3. Disposal of used electrical equipment.
4. Additional documentation and/or user manual.
5. Keep tidy.
6. Recycling code (corrugated fiberboard (cardboard)).

2. CHARACTERISTICS OF THE SET

The AVONI video doorphone set is a modern solution for single-family buildings, combining security and convenience. It consists of a 7-inch touchscreen monitor and an outdoor unit equipped with a high-resolution 2K camera, RFID reader, and IR night illumination. The intuitive 4-wire connection enables quick and easy installation, while control of the wicket and gate does not require an additional power supply. Wi-Fi functionality and integration with the Tuya Smart app allow remote operation from anywhere. The system supports microSD cards and enables recording of photos, videos, and conversations. The outdoor unit housing is made of high-quality aluminum, resistant to weather conditions, and suitable for surface mounting. The system can be expanded to include up to 4 monitors, 2 outdoor units, 2 CCTV cameras, and 4 IP cameras.

Included: monitor (1 pc), power supply (1 pc), monitor mounting frame (1 pc), outdoor unit (1 pc), outdoor unit rain cover (1 pc), outdoor unit mounting frame (1 pc), outdoor unit front cover (1 pc), flush-mount box for outdoor unit (1 pc), security screw (1 pc), screws (6 pcs), wall plugs (6 pcs), Allen key (1 pc), 4-pin connector (3 pcs), 3-pin connector (1 pc), RFID tags (7 pcs).

3. INTENDED USE

The video doorphone is designed for installation in single-family buildings. The outdoor unit is suitable for surface mounting outdoors, while the monitor is intended for surface mounting in indoor environments. The system enables remote communication, access control, and control of the electric strike and gate, making it an ideal solution for detached houses and other facilities requiring effective access control.

4. TECHNICAL DATA

TYPE OF THE DEVICE:	single-family
INSTALLATION METHOD:	4-wire
COMMUNICATION SYSTEM:	wireless – monitor and Wi-Fi router, wired – monitor and outdoor unit
WLAN FREQUENCY:	2.400-2.483,5 MHz or 5 GHz (802.11 b/g/n)
MAXIMUM TRANSMITTING POWER:	<100 mW EIRP
COMPATIBILITY WITH OPERATING SYSTEM:	Android (v6.0 or newer); iOS (13.0 or newer)
POWER CONSUMPTION IN OFF-MODE:	n/a
POWER CONSUMPTION IN STANDBY MODE WHEN CONNECTED TO THE NETWORK:	5 W
TIME TO REACH THE STANDBY MODE:	30 s

MONITOR

SCREEN SIZE:	7"
RESOLUTION:	1024 × 600
FUNCTIONS:	call, monitoring, door and gate control, monitor and volume control, mute mode, intercom, digital frame, answering machine, SD card reader
NUMBER OF MELODIES:	6
VOLUME CONTROL:	yes
CALL TIME:	120 s
MONITORING TIME:	60 s
POWER SUPPLY:	15 V DC 1 A
POWER CONSUMPTION:	standby <3 W; work <6,6 W
ELECTRICAL STRIKE CONTROL:	yes (12 V DC max. 350 mA)
GATE CONTROL:	yes (dry contact)
WORKING TEMPERATURE:	-20°C – +50°C
INSTALLATION:	surface-mounted
MATERIAL:	plastic
DIMENSIONS:	181 x 181 x 18 mm
NET WEIGHT:	0.38 kg

OUTDOOR UNIT

SENSOR TYPE:	CMOS 1/3"
RESOLUTION:	2K, 2560×1440
VIEWING ANGLE (VERTICAL/HORIZONTAL):	54° / 112°
NIGHT LIGHTING:	IR diodes
NUMBER OF DIODES:	4
NIGHT VISION RANGE:	approximately 1 m
RFID READER:	119-128.6 kHz RFID-tags/cards (max. 24 users)
MOTION SENSOR:	yes
INGRESS PROTECTION:	IP65
POWER SUPPLY:	15 V DC from monitor
POWER CONSUMPTION:	standby <3 W, work <4 W
WORKING TEMPERATURE:	-20°C – +50°C
INSTALLATION:	surface-mounted
MATERIAL:	aluminum
DIMENSIONS:	87 × 168 × 40 mm
NET WEIGHT:	0.21 kg

5. SET CONSTRUCTION

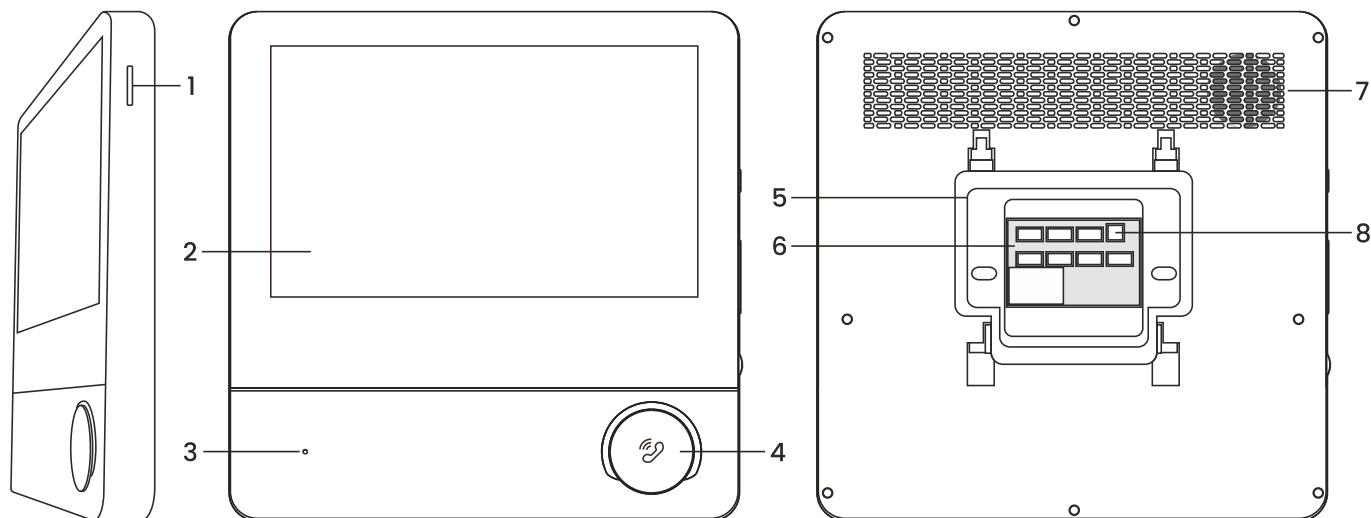

fig. 1 Construction of the monitor

MONITOR

- | | | |
|----------------------|------------------------|----------------|
| 1. MicroSD card slot | 4. Answer/end a call | 7. Speaker |
| 2. LCD touchscreen | 5. Mounting frame slot | 8. Power input |
| 3. Microphone | 6. Connection ports | |

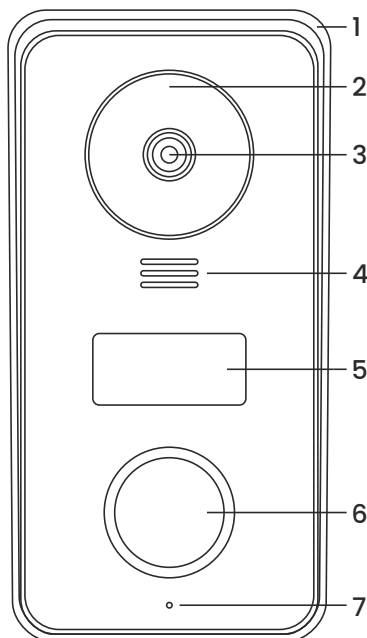

fig. 2 Construction of the outdoor unit

OUTDOOR UNIT

- | | | |
|-----------------------|----------------|---------------|
| 1. Rain cover | 4. Speaker | 7. Microphone |
| 2. Night illumination | 5. RFID reader | |
| 3. Camera lens | 6. Call button | |

6. INSTALLATION

MONITOR INSTALLATION

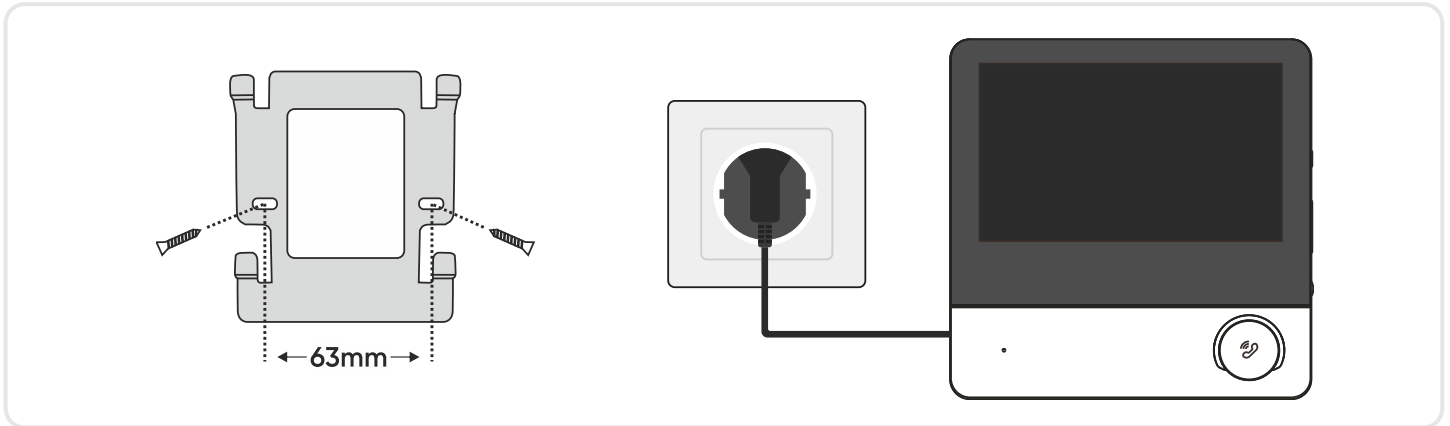

fig. 3 Monitor installation

1. Drill holes in the wall and insert wall plugs into them.
2. Insert the screws into the holes, but do not tighten them fully against the wall. The recommended distance from the wall is approx. 5 mm.
3. Hang the monitor on the protruding screws.
4. Connect the power supply to the 230 V AC outlet.

The device should not be installed in the vicinity of other equipment that may be a source of strong radiation (TV, DVR, etc.). During installation, make sure not to pinch the wires in the mounting bracket. Do not force the monitor onto the mounting bracket.

OUTDOOR UNIT INSTALLATION

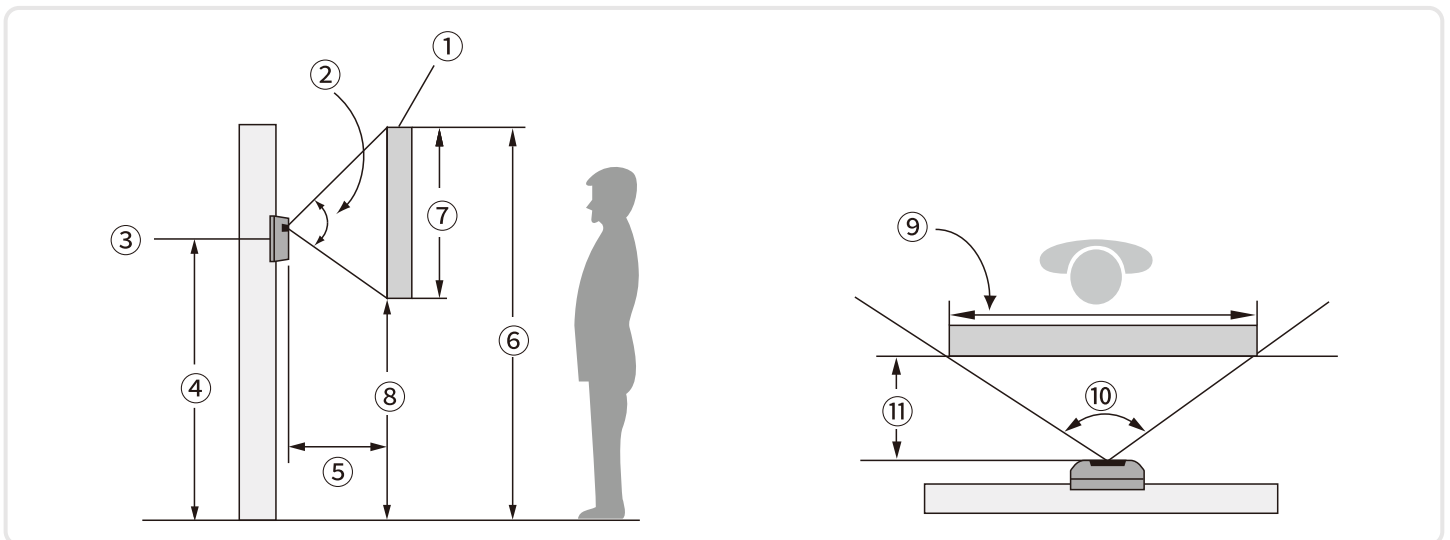

fig. 4 Outdoor unit placement

Example diagram of installation position and camera recording ranges (the measurements provided are approximate and may vary depending on environmental conditions.) 1. Vertical recording range. 2. Camera viewing angle (vertical – 54°). 3. Outdoor unit. 4. Recommended mounting height of the outdoor unit (approx. 145 cm). 5. Distance from the camera (approx. 50 cm). 6. Upper limit of the vertical recording range (approx. 181 cm). 7. Height of the recorded area (approx. 84 cm). 8. Lower limit of the vertical recording range (approx. 97 cm). 9. Horizontal recording range. 10. Camera viewing angle (horizontal – 112°) 10. Recommended distance from the camera to the observed objects (approx. 50 cm).

Do not install the device close to sources of strong radiation, e.g. hoists and other drive systems powered by alternating current. • Do not install the outdoor unit in a location with harsh weather conditions, e.g.: heavy rainfall, high temperature, high humidity, high dust, presence of corrosive chemicals. • The device should be mounted in a location and position that provides an optimal field of view.

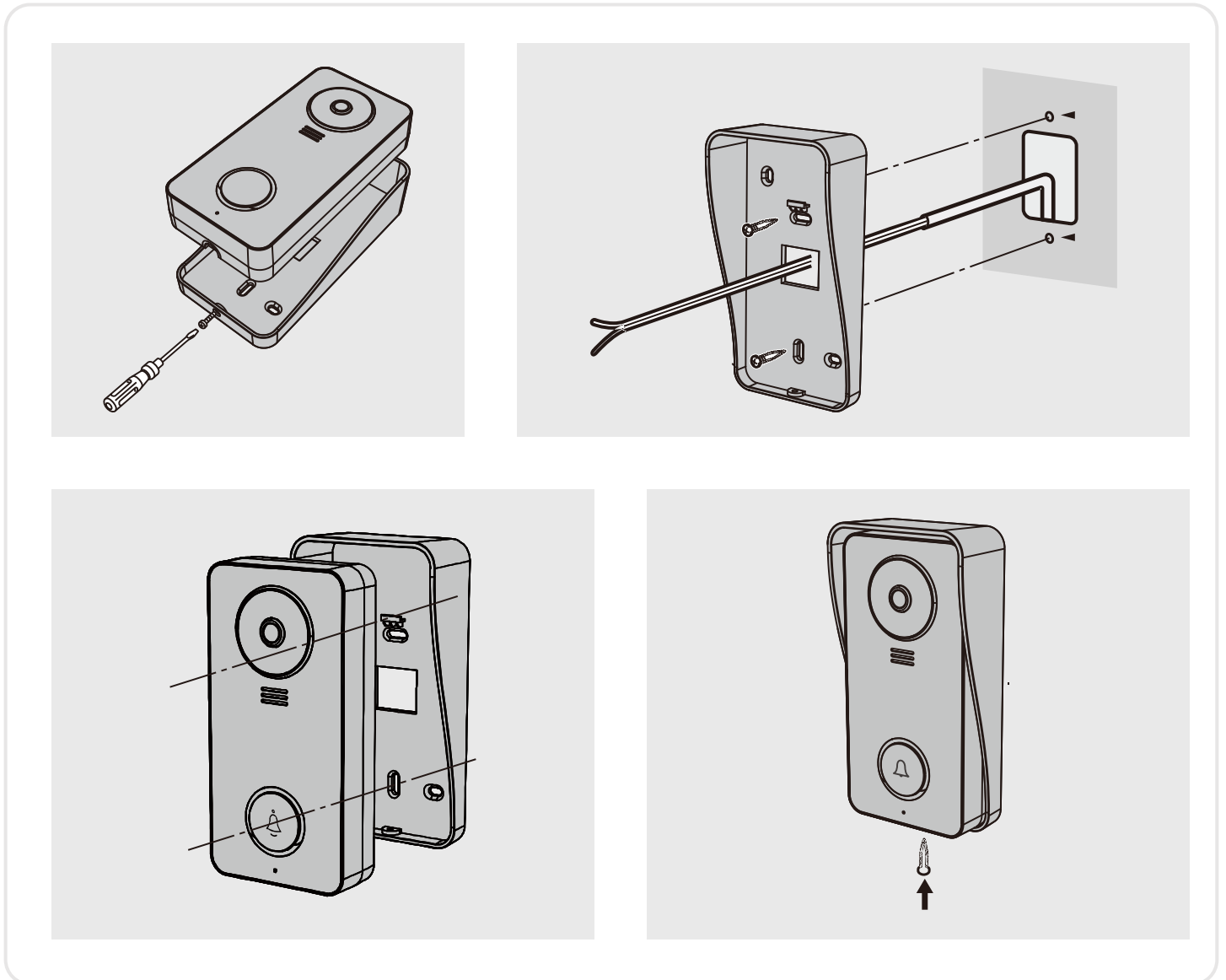

fig. 5 Surface-mounted installation of the outdoor unit

1. Unscrew the security screw and separate the outdoor unit from the protective cover.
1. Drill holes in the wall and insert the silicone wall plugs.
2. Route the cables through the opening in the protective cover, then secure the cover in the selected location.
3. Connect the wires to the outdoor unit according to the wiring diagram.
4. Place the outdoor unit into the protective cover and secure it by tightening the security screw from the bottom.

7. WIRING DIAGRAMS

Before drilling the installation holes, it is recommended to carry out a functional test of the device. To do this, connect the device for a test according to the wiring diagram. The first person holding the camera should use the button to call the second person who is at the monitor. This person should then carefully inspect the camera's field of view in order to correct the module's position if necessary. Once the measurements have been taken accurately, proceed with the mounting holes after switching off the power supply.

It is forbidden to make connections to live equipment! Failure to adhere to this recommendation may result in permanent damage to the device and loss of health.

The set does not include an electric door strike, cameras, exit button, and automatic gate control unit!

The electric strike/alarm/camera is not included in the set. You must purchase an electric strike that best suits the requirements of the set (12 V DC max. 350 mA). In the standard model, the system works with strikers that open with a NO contact. This means that in normal operation, the circuit is open, so the striker is permanently closed. When the entry button is pressed and there is a change on the dry contact, the striker is released.

The video doorphone cables should not be routed in one cable with the cables of other installations such as bell, alarm, etc. Any power and telecommunication cables emitting strong magnetic fields (e.g. loudspeaker columns, TV set) in direct contact with the cables connecting the outdoor unit to the monitor may adversely affect the operation of the set. If the user has other connection cables than the recommended ones, it is allowed to use them, however, it is necessary to make a test connection of the set in order to check its correct functioning.

While designing the wiring system, take into account the suitable cross-section of cables:

Up to 30 m recommended cable XzTKMXpw 3 × 2 × 0.5 mm

From 30 m to 100 m recommended cable XzTKMXpw 3 × 2 × 0.8 mm

The connection to the electromagnetic lock should be made with 2 × 1mm² cable. The set is compatible with any electric door strike with 12 V DC supply voltage and current consumption of max. 350 mA. The total length of the installation must not exceed 100 meters. We absolutely do not recommend the use of twisted-pair cables.

8. OPERATION

CALL

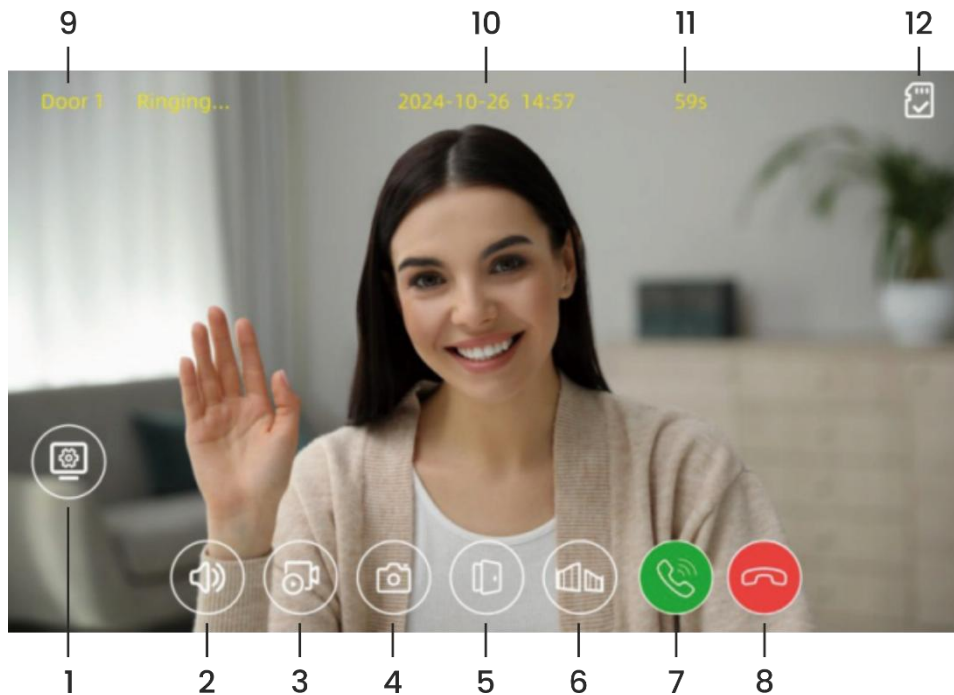

When the call button on the outdoor unit is pressed, the camera view will appear on the monitor. The resident can answer the call within 60 seconds (this value can be changed in the settings). If automatic recording is enabled, a photo or video will be saved when the call button is pressed. After answering the call, the resident can talk to the visitor, open the wicket or gate, and save additional photos or recordings. The call can last for a maximum of 120 seconds. If a call from another outdoor unit is initiated during an active conversation, it will interrupt the current call and connect to the monitor.

- 1 Opens the image adjustment menu. Adjust brightness, contrast, and saturation as needed.
- 2 Displays the call volume adjustment slider.
- 3 Select to manually save a video of the current view (requires an SD card).
- 4 Select to manually save a photo of the current view (requires an SD card).
- 5 Select to open the wicket.
- 6 Select to open the gate.
- 7 Start a conversation.
- 8 End the conversation.
- 9 Displays the name of the device from which the image is shown.
- 10 Displays the current date and time.
- 11 Displays the remaining call time (maximum 120 seconds).
- 12 Displays the SD card status.

MAIN SCREEN



- 1** Before pairing with a phone: displays QR codes for pairing with the app.
After pairing with a phone: starts an intercom call with the paired phone.
- 2** Open the live view from the outdoor unit and IP cameras.
- 3** Open the intercom menu. Function available when additional monitors are connected.
- 4** Open the gallery of saved photos and recordings.
- 5** Open the alarm settings.
- 6** Open the video door phone system settings.
- 7** Displays the current time, date, and weather forecast.
- 8** SD card status indicator.
- 9** Wi-Fi connection status indicator.
- 10** Smartphone connection status indicator.
- 11** Open the information menu.
- 12** Silent mode indicator.
- 13** Answering machine indicator.
- 14** Screen sleep button.

APP

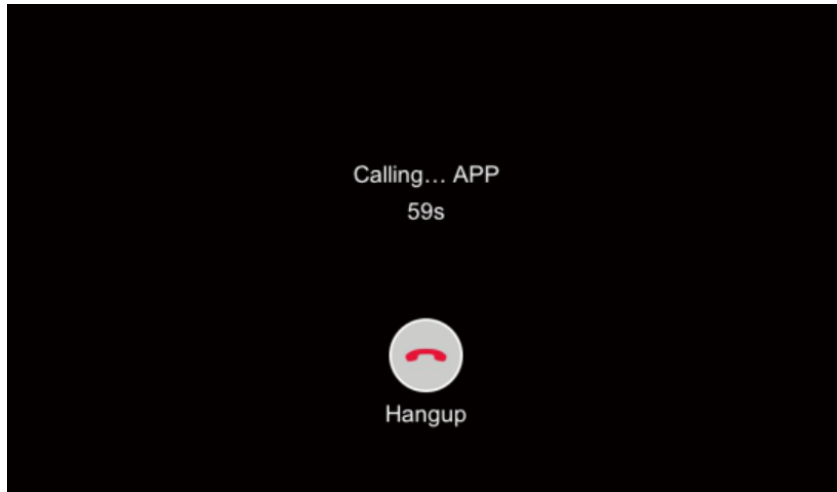

Before pairing with a phone

Displays two QR codes used for pairing the system with a smartphone. The left QR code allows you to download the Tuya Smart app, while the right QR code is used to pair the system with the application.

After pairing with a phone





Selecting the *App* tab will initiate a call between the monitor in use and the paired smartphone with the installed app.

CAMERA

Selecting the *Camera* tab opens the monitoring menu. Choose the device from which you want to view the live image — outdoor unit, CCTV camera, or IP camera. The system supports up to two outdoor units, two CCTV cameras, and four IP cameras connected via the ONVIF protocol. **Note:** This function will not work if no outdoor unit or camera is connected to the system.

The system supports only IP cameras up to 4MP with full ONVIF protocol support. For proper monitoring operation, ensure that both the monitor and the IP camera are connected to the same Wi-Fi network. It is also possible to connect the IP camera to the same router used by the system — in this case, the system will automatically detect the camera via ONVIF.

Note: IP cameras from popular brands such as Hikvision, Dahua, and TP-Link typically support ONVIF. Most Tuya Wi-Fi cameras, however, do not support ONVIF and therefore are not compatible with this system.

Use the < > buttons to scroll through pages. Select the icon of one of the connected devices  /  /  to open the camera view. Return to the main menu by clicking .

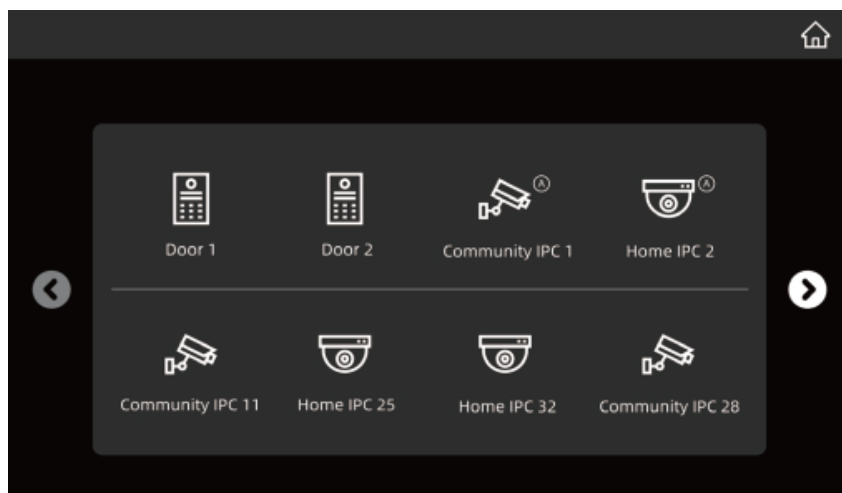

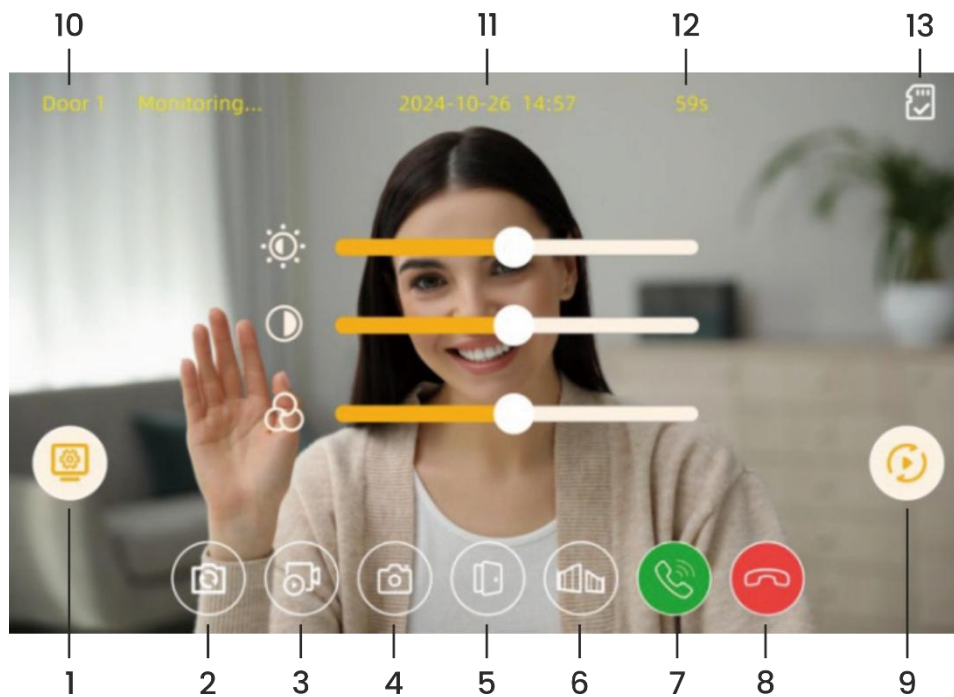

- 1** Opens the image adjustment menu. Adjust brightness, contrast, and saturation as needed.
- 2** Switch the live view to the next connected device (requires at least 2 connected outdoor units/cameras).
- 3** Select to manually save a video of the current view (requires an SD card).
- 4** Select to manually save a photo of the current view (requires an SD card).
- 5** Select to open the wicket.
- 6** Select to open the gate.
- 7** Start a conversation.
- 8** End the conversation.
- 9** Automatic monitoring – automatically cycles through all connected cameras. While this function is enabled, photos/videos of the current view will be recorded automatically.
- 10** Displays the name of the device from which the image is shown.
- 11** Displays the current date and time.
- 12** Displays the sequence time for automatic monitoring (maximum 60 seconds).
- 13** Displays the SD card status.

INTERCOM

Selecting the *Intercom* tab will open the intercom menu. Choose the monitor you want to call. You can call all monitors connected to the system – the conversation will be established with the monitor that answers first. Return to the main menu by clicking .

After the call begins, the screen will display the remaining call time (maximum 120 seconds), the volume adjustment slider, and the end-call icon.

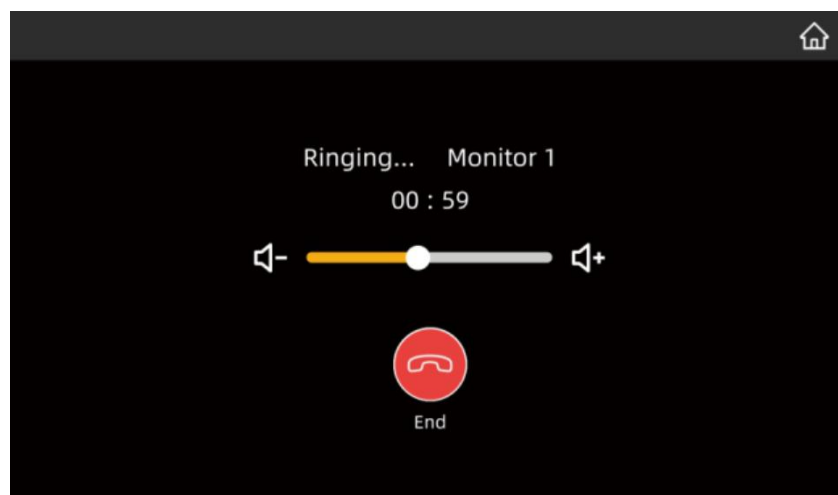
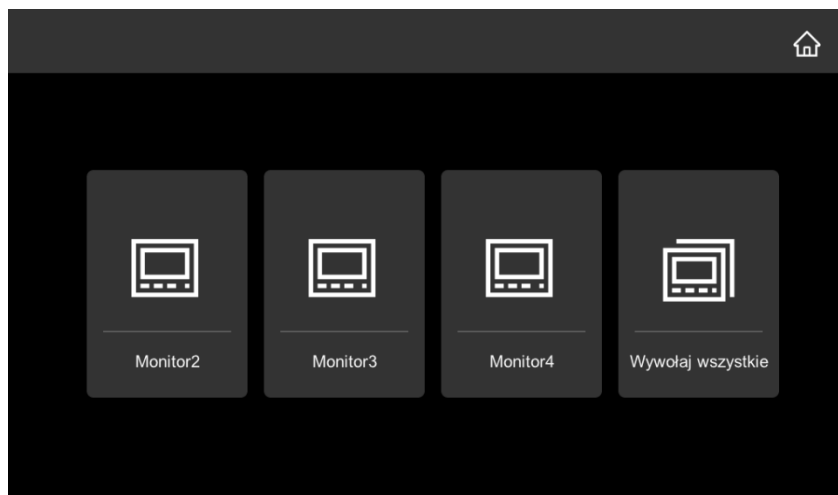

HISTORY

Selecting the *History* tab opens the folder containing saved files. Choose the file you want to open.



- 1 Files saved during a call.
- 2 Files saved after missed calls.
- 3 Files saved after motion detection.
- 4 Files saved by the answering machine function.
- 5 Files saved during an alarm.
- 6 Use the < > buttons to go to the previous or next page.
- 7 Displays the current page and the total number of pages.
- 8 Return to the main menu.
- 9 Delete all files from the device memory.
- 10 Displays the source (device) from which the file was recorded.
- 11 Displays the date and time when the file was saved. A red dot next to the date indicates new (unopened) files.
- 12 Delete the selected file from the device memory.
- 13 Displays the actions performed when the file was saved (e.g., gate or wicket being opened).

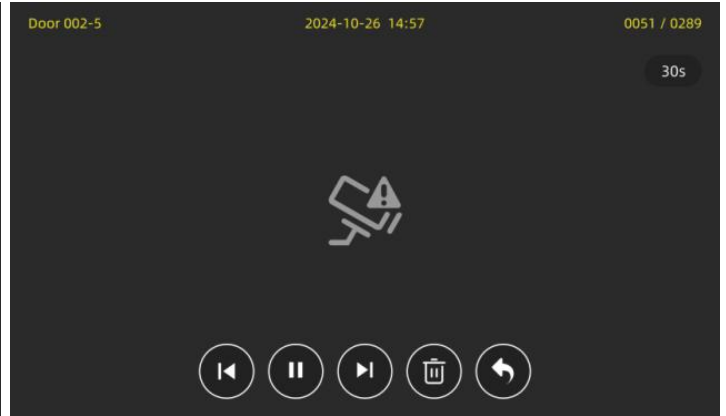
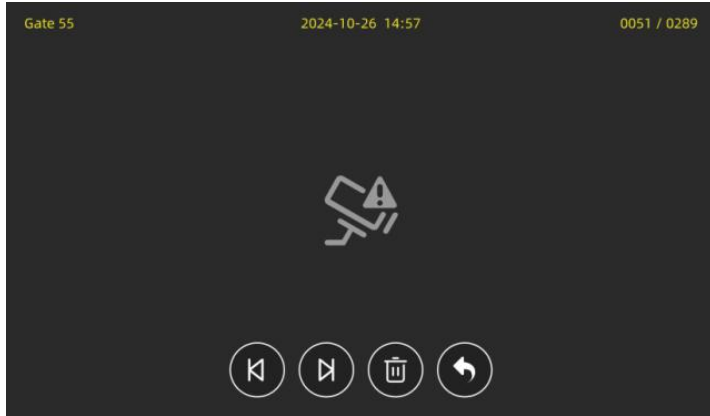

After opening a file, the top bar will display the recording source, the date and time of the recording, and the page number. The bottom buttons are used to switch to the next/previous file, pause playback (for video recordings), delete the opened file, and return to the file list.

ALARM

Selecting the *Alarm* tab opens the alarm menu. The alarm function has three operating modes: Home mode, Away mode, and Off mode. To select any operating mode, you must enter the password set in the system settings. After choosing a mode and confirming it with the password, the delay countdown will begin. Detailed alarm settings can be adjusted in the system settings (see page 21).

If a security alarm is triggered, the screen will display the sensor number and the event time. Once the emergency situation has been resolved, press the Yes button at the bottom of the screen to deactivate the alarm. Deactivation requires password confirmation.

If an alarm occurs, the system automatically saves a snapshot from the camera assigned to the alarm. If no camera is assigned to the alarm, black images will be saved. Saved photos can be viewed in the *Alarm* folder under the *History* tab. After opening a file, the top bar will display the recording source, the date and time of the recording, and the page number. Below, the alarm type and mode will be shown. The bottom buttons are used to switch to the next/previous file, pause playback (for video recordings), delete the opened file, and return to the file list.

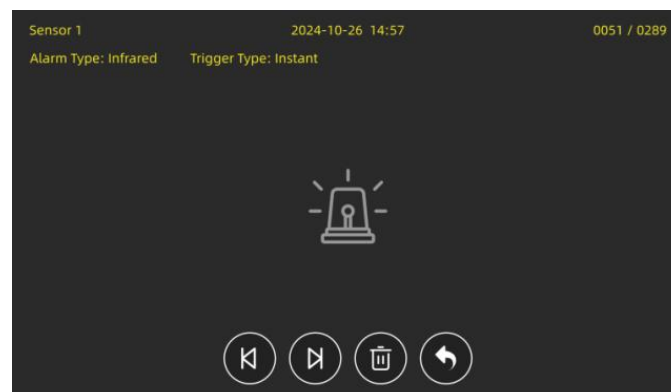
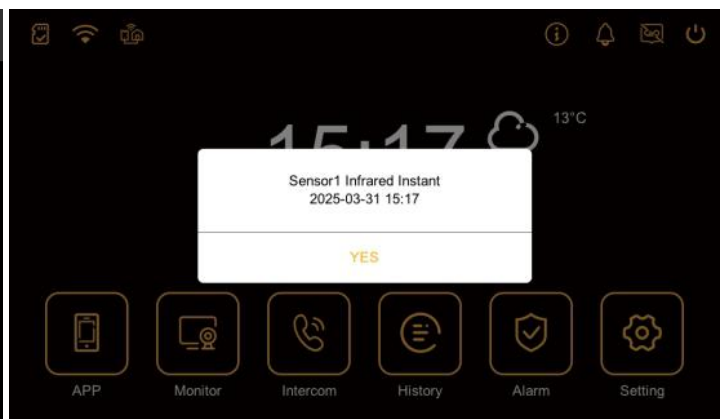
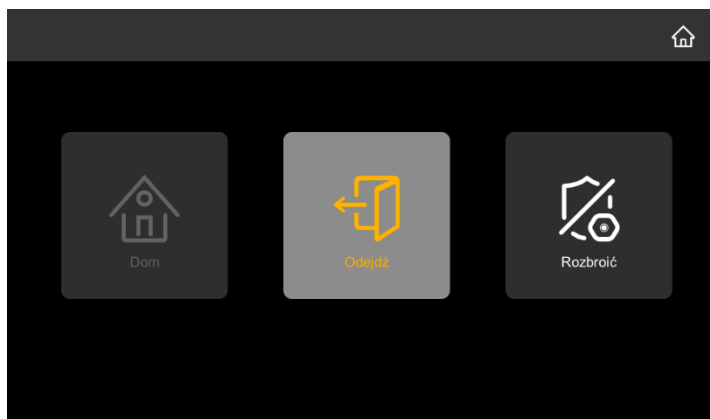

9. SYSTEM SETTINGS

BASIC

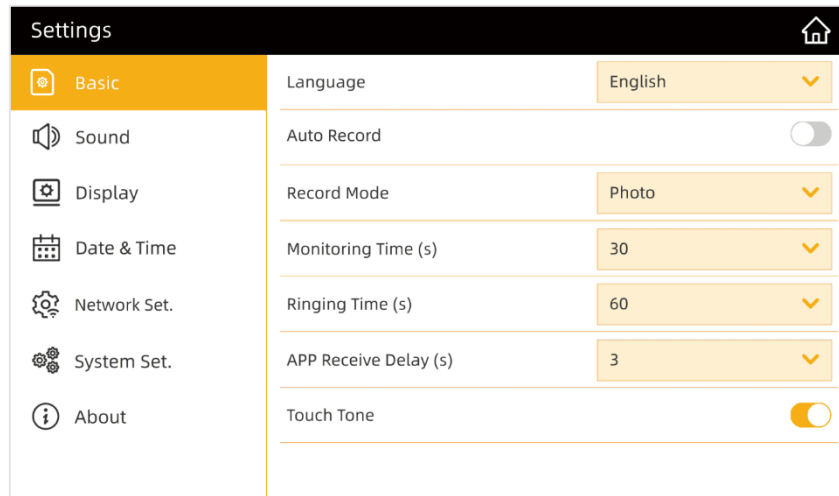

Language Select the system language.
Available languages: Chinese, English, Polish, Russian, Spanish, German, and Arabic.

Automatic recording Enable automatic recording of photos/videos.

Recording mode Select the automatic recording mode: photo or video.
Note: Video recording mode is available only when an SD card is inserted in the monitor.

Monitoring time Set the duration of automatic monitoring. Options: 10 / 30 / 60 seconds.

Call time Set the call waiting (ringing) duration.

App delay Set the delay time for sending notifications to the smartphone app.

Key tones Enable or disable key tones on the monitor.

SOUND

For each of the four time periods, you can set separate ringing schemes. The time periods themselves can also be freely adjusted to your needs.

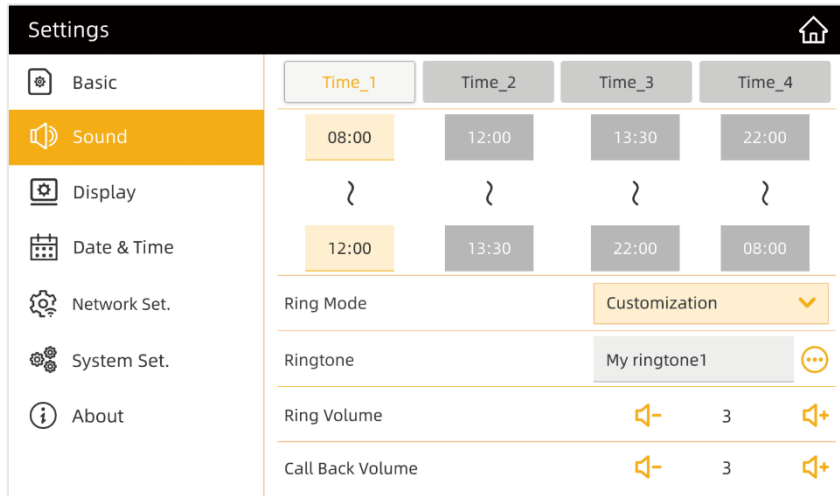

Ringtone mode	Choose one of two ringtone modes: Standard: select a ringtone from the system sound files. Custom: select a ringtone from MP3 files saved on the SD card (MP3 melodies must be placed in the music folder on the SD card).
Ringtone	Select one of the 6 system ringtones (standard mode) or one of the saved MP3 files (custom mode) as the doorbell sound.
Ringtone volume	Adjust the ringtone volume.
Call volume	Adjust the ringtone volume during an intercom call from the phone.

DISPLAY

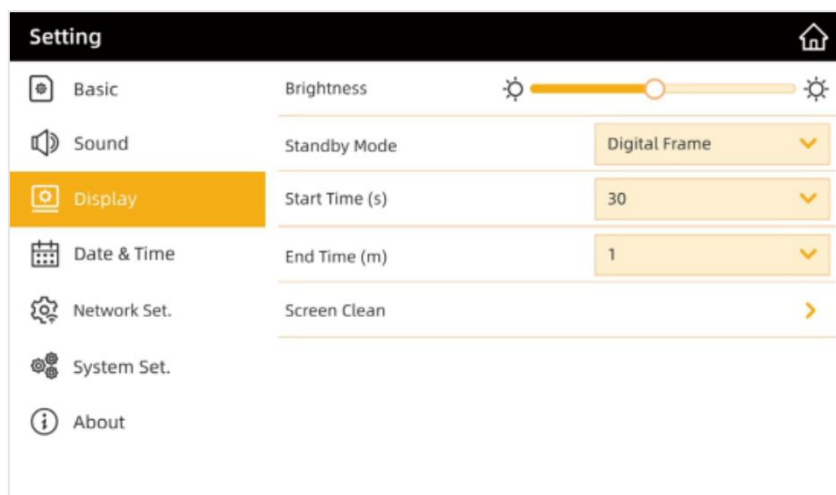

Brightness Adjust the screen brightness.

Standby mode Choose one of the available standby modes:
 Black screen: the screen turns off when entering standby mode.
 Date and time: the screen displays the current date and time in standby mode.
 Digital photo frame: the screen displays images saved on the SD card when in standby mode. Images must be in JPG or JPEG format and placed in the *picture* folder on the SD card. Maximum image resolution: 2048 × 1152 px; minimum: 103 × 60 px. Up to 50 images can be stored in the folder.
Note: the digital photo frame function is disabled when motion detection is enabled.

Screen timeout Set the time (in seconds) after which the screen enters standby mode.

Digital photo frame sequence time Set the duration (in minutes) of the digital photo frame sequence.

Screen cleaning After selecting cleaning mode, the touchscreen is deactivated for 30 seconds. During this time, you can wipe the screen with a dry cloth. This function cannot be interrupted before it is completed.

DATE AND TIME

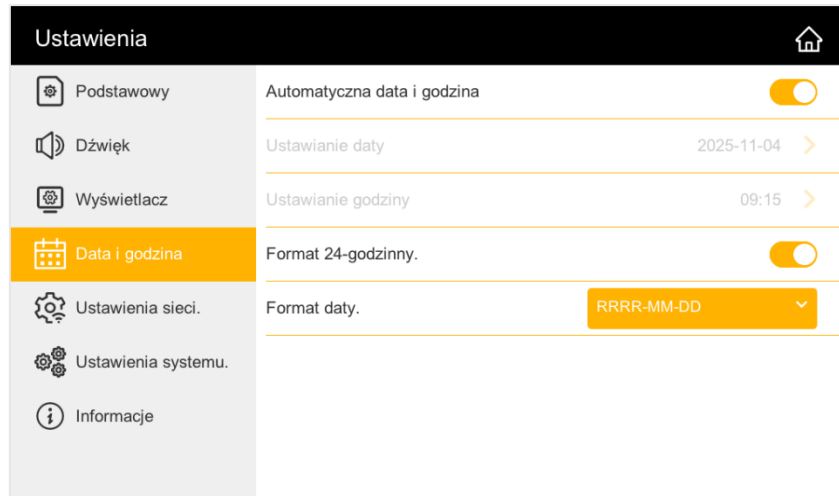

Automatic date and time

Enable or disable automatic synchronization of date and time with the paired smartphone.

Set date and time

Manually set the date and time (available only when automatic date and time is turned off).

Time format

Choose a 12-hour or 24-hour time format.

Date format

Choose a date format:

DD-MM-RRRR / DD-RRRR-MM / MM-DD-RRRR / MM-RRRR-DD / RRRR-DD-MM / RRRR-MM-DD.

NETWORK SETTINGS

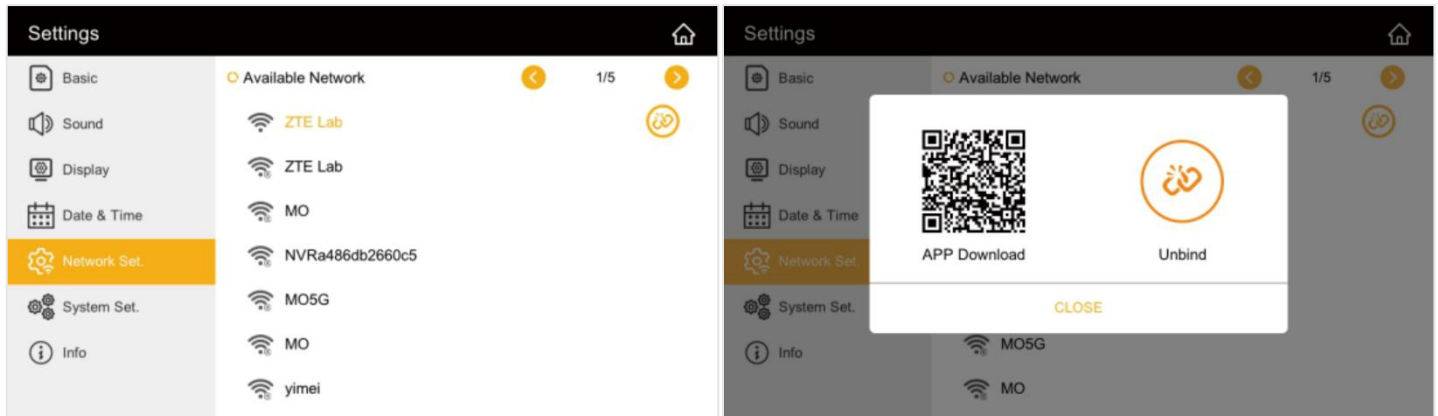

This tab allows you to connect the device to a Wi-Fi network. Select your home network from the list of automatically detected networks and enter the password to connect. After connecting to the Wi-Fi network, tap the network name again to display the QR code for downloading the application. Next to it, a code required for pairing the device with a smartphone will be displayed. Once the devices are paired, the pairing QR code will change into an unpairing option (*Unbind*).

Note: the device can be paired with only one Tuya account. To pair it with a new account, you must remove the pairing from the previous account or share the device with another account (home management tab). In case of product return or service repair, the device must be removed from the Tuya Smart app and restored to factory settings.

SYSTEM SETTINGS

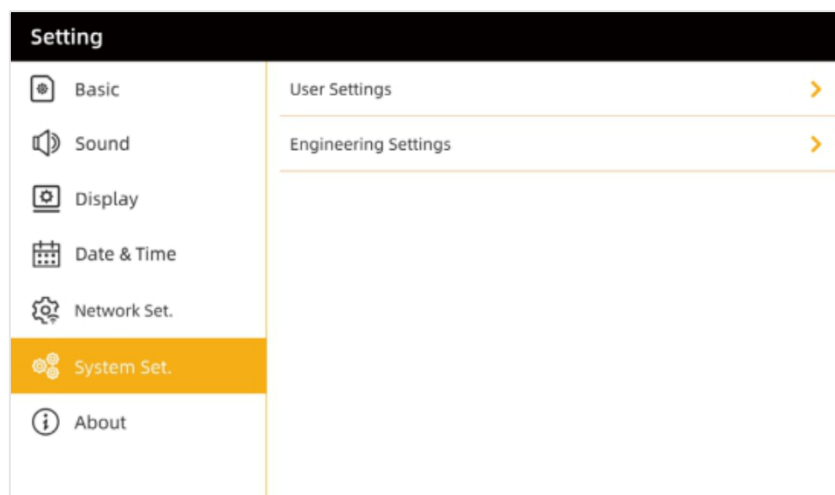

This tab allows you to change the system settings. Before opening specific settings, you must enter the user password (for user settings) or the technical password (for technical settings). The default password is: 123456.

SYSTEM SETTINGS – USER SETTINGS – MOTION DETECTION

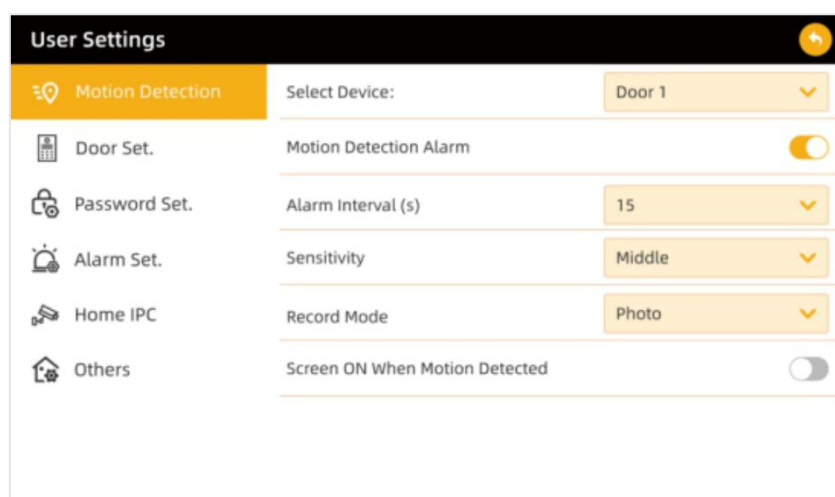

Select panel Choose the device for which you want to edit motion detection settings.

Motion detection Enable or disable motion detection for the selected device.

Detection interval Select the delay time between subsequent motion detections.

Sensitivity level Choose one of three motion detection sensitivity levels: low, medium, or high. The higher the sensitivity, the smaller the movement required to trigger the function.

Recording mode Select the motion detection recording mode: photo or video.

Screen on after motion detection When enabled, the monitor will automatically display the live view from the device that detected motion.

Note: with motion detection enabled, the outdoor unit's night illumination will always turn on after sunset. After motion is detected, a push notification will be sent to the smartphone paired with the system. Motion detection is not recommended if the device is pointed toward an area with heavy traffic, as this may lead to frequent push notifications and excess recordings. This product is a video door phone system and is not intended to replace a full DVR system.

SYSTEM SETTINGS – USER SETTINGS – DOOR SETTINGS

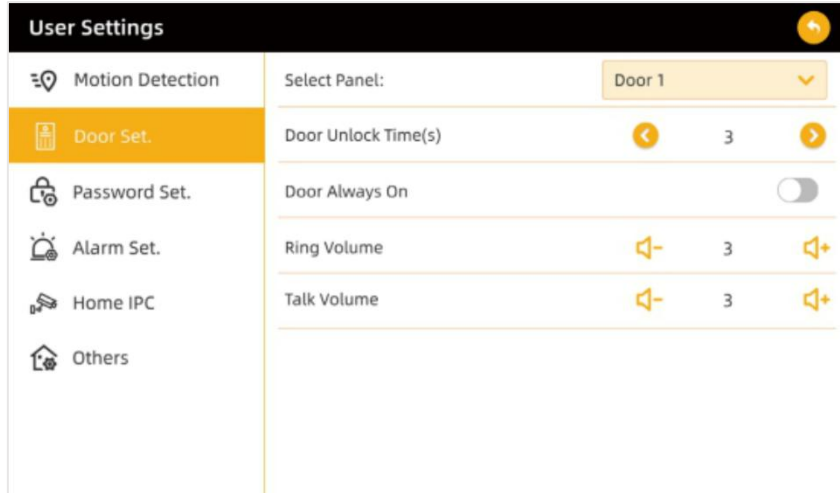

Select panel Choose the device for which you want to edit the settings.

Unlock time Adjust the opening time of the electric strike (wicket).

Door always on Enable or disable the RFID panel.
When this function is disabled, the wicket can only be opened from the monitor.

Ringtone volume Adjust the ringtone volume on the outdoor unit.

Call volume Adjust the call volume on the outdoor unit.

SYSTEM SETTINGS – USER SETTINGS – PASSWORD SETTINGS

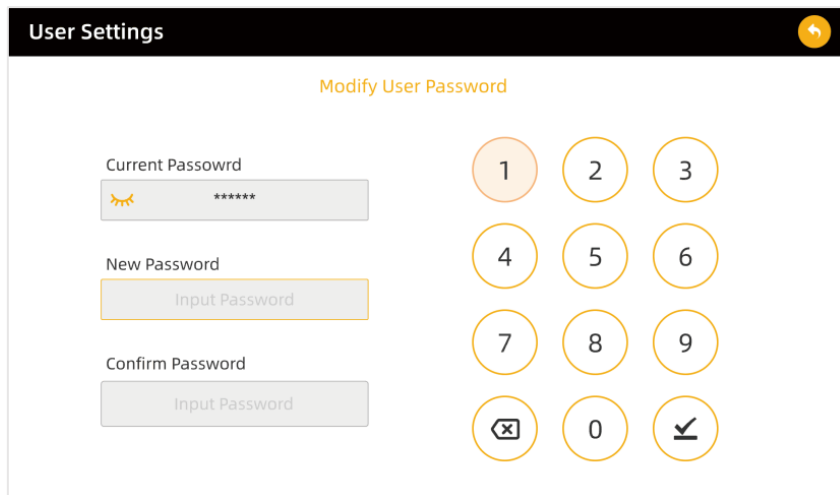

This tab allows you to change the user password. To change the password, enter the current user password (default: 123456), then enter the new password and confirm it. If the current user password is lost, the entire system must be restored to factory settings, or the password must be reset in the technical settings (see page 25).

SYSTEM SETTINGS – USER SETTINGS – ALARM SETTINGS

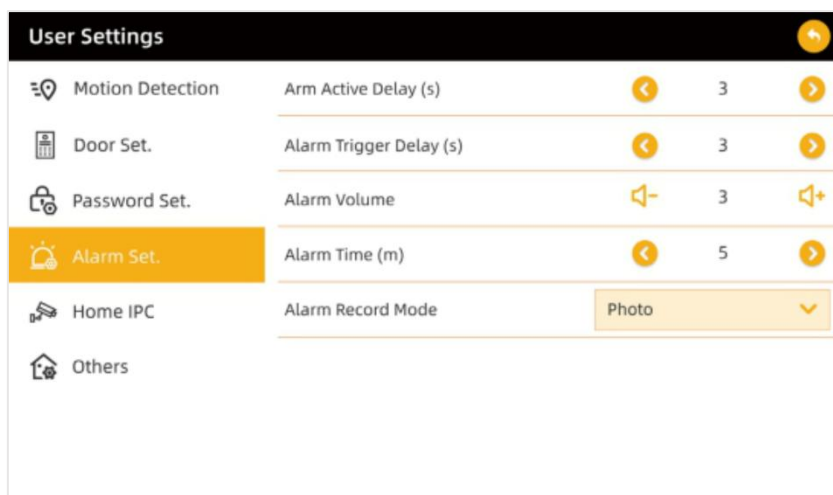

Arming delay Adjust the delay time before the alarm is activated.

Alarm trigger delay Adjust the delay time before the alarm is triggered after motion is detected.

Alarm volume Adjust the alarm volume.

Alarm duration Adjust the duration of the alarm.

Alarm recording mode Select the recording mode during an alarm: photo or video.

SYSTEM SETTINGS – USER SETTINGS – IPC MONITORING

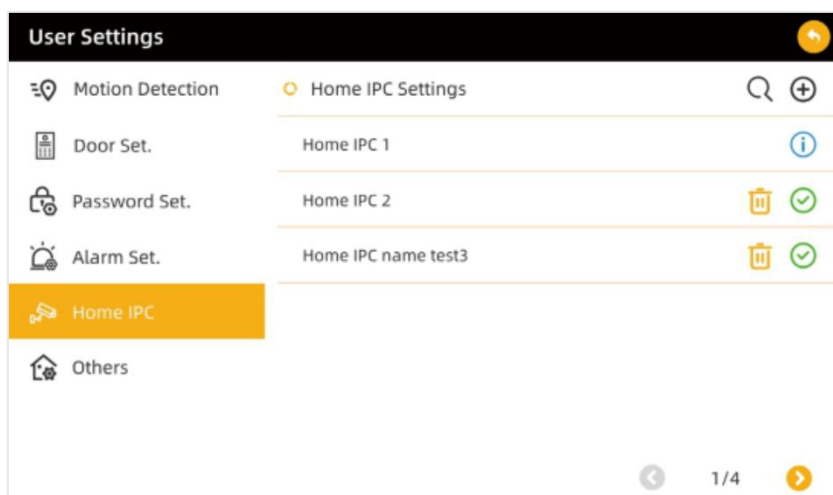

This tab allows you to manage IP cameras. The system supports up to 4 IP cameras. Press to search for nearby IP cameras. Click next to the device name to connect it to the system, assign a custom name, and authorize the connection by entering the IP camera's username and password. IP cameras can also be added manually by clicking . Then enter the device name and the camera's video stream URL. After adding an IP camera, you can use the trash can icon to remove any devices you no longer use.

Note: the maximum supported camera resolution is 2048 × 1152, and H.265 encoding is required.

SYSTEM SETTINGS – USER SETTINGS – OTHER

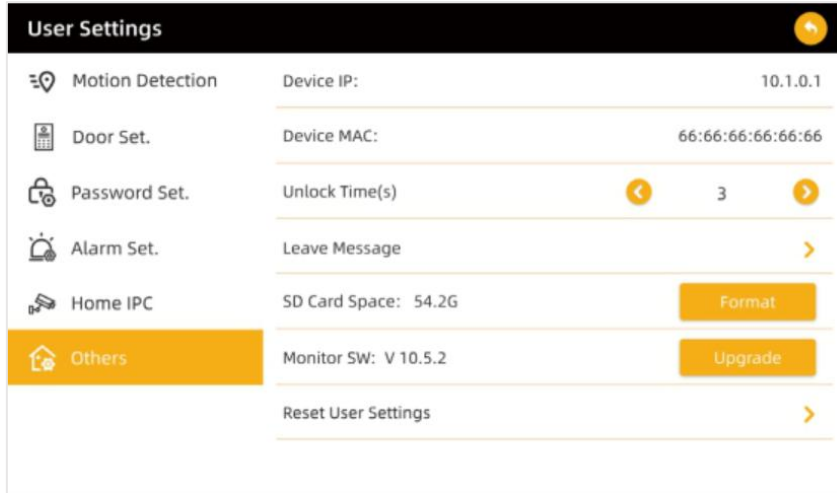

Device IP and MAC address

Displays the device's IP and MAC address.

Gate opening time

Adjust the gate opening duration.

Answering machine

Enable or disable the answering machine function. When enabled, you can set the answering machine delay time (the message can be played after 3 / 10 / 20 / 30 seconds of ringing). Press *REC* to start recording the message, pause with *||*, and play it back with *▶*. Confirm the finished recording by pressing *YES*.

SD card storage

Displays the remaining free space on the installed SD card. When inserting a new SD card into the monitor, use the *FORMAT* button to format the card and prepare it for use.

Software version

Displays the installed firmware version. To update the software, place the update files on the SD card and press *UPGRADE*.

Reset user settings

Resets all user settings.

SYSTEM SETTINGS – TECHNICAL SETTINGS – DEVICE ID

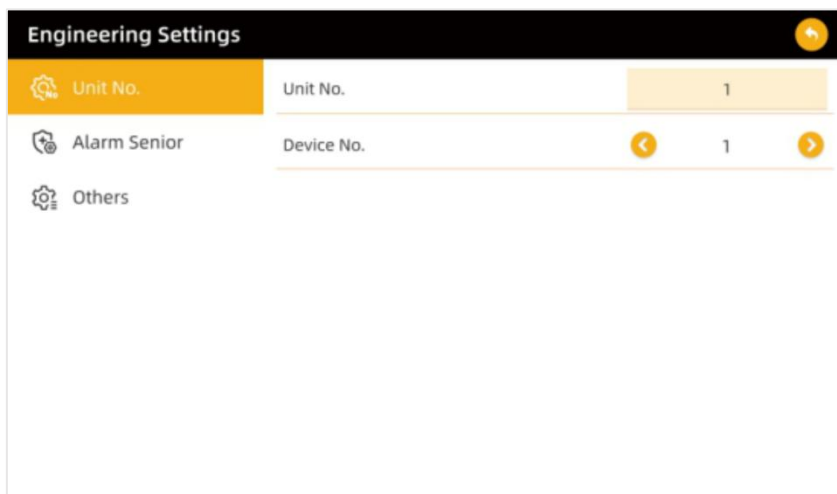

This tab allows you to manage the device ID number. When additional monitors are connected, each monitor must be assigned a unique ID.

SYSTEM SETTINGS – TECHNICAL SETTINGS – ALARM SETTINGS

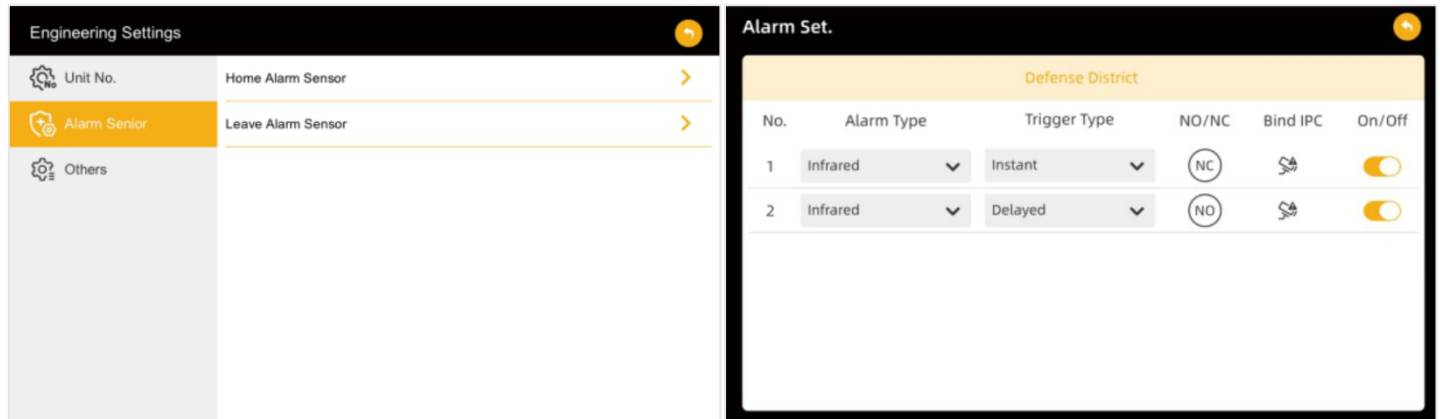

This tab allows you to manage alarms. Select *Home mode alarm* or *Away mode alarm* to configure how the alarms operate in the chosen mode. On the displayed screen, adjust the following settings: alarm type (infrared / gas / smoke / door magnetic / window magnetic / SOS / other), response time (delayed / immediate / 24-hour immediate), alarm contact type (NO – normally open / NC – normally closed) and bind the alarm to a selected IP camera. Additional alarm settings can be configured under: *SYSTEM SETTINGS – USER SETTINGS – ALARM SETTINGS*.

SYSTEM SETTINGS – TECHNICAL SETTINGS – OTHER

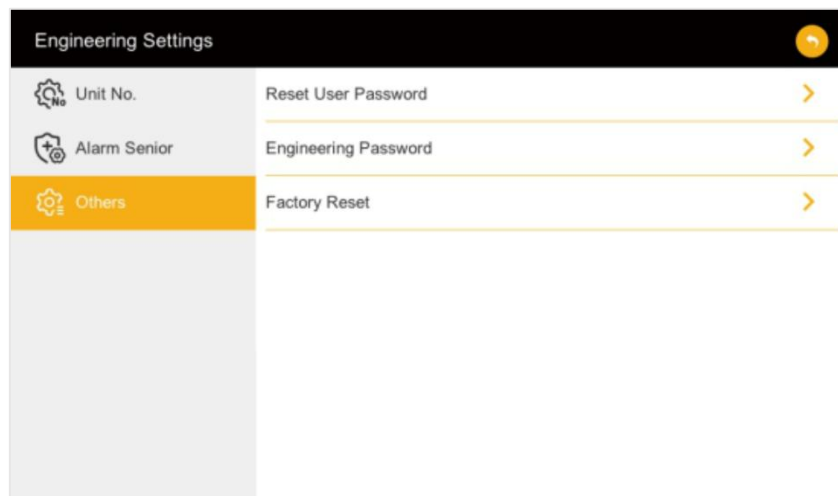

This tab allows resetting the user password, changing the technical password, and restoring the system to factory settings.

15. WI-FI CONNECTION

Note: a device can only be paired with one Tuya account. To pair the device with a new account, remove the pairing with the previous account or use the share function in the app to make the device available for a second account.

1. Open the App Store (iOS) or Google Play (Android) on your phone. Search for the app *Tuya Smart* and install it or scan the QR code.
2. If you do not already have an account in the app, click *Sign up*, you will be redirected to the next page. The system will automatically identify the country/region you are from or you can manually select it yourself. Enter your e-mail address, check your agreement with the privacy policy and click on *Receive verification code*. Enter the code you received, then enter your password and click *Go to app*.

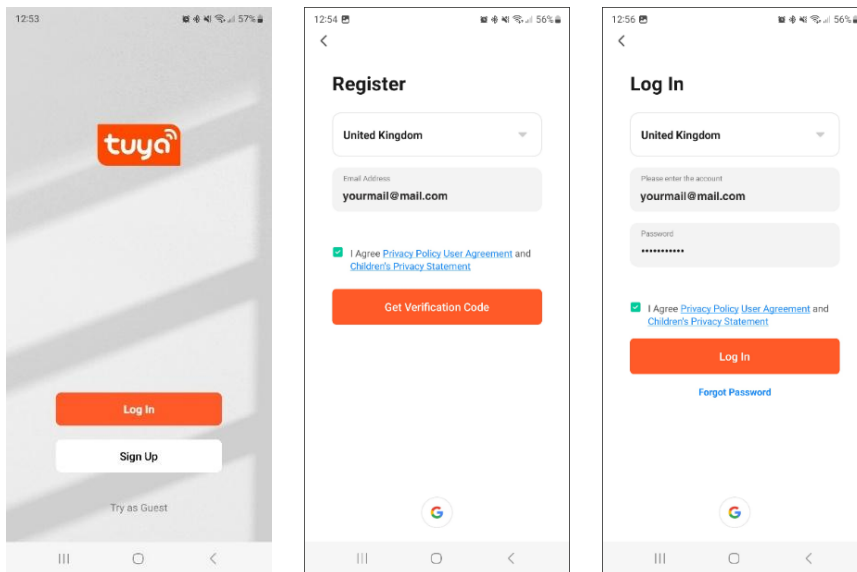

3. On the monitor, select *Settings > Network Settings* and connect the monitor to your home Wi-Fi network (the same one your phone is connected to) by selecting it from the list and entering the password.
4. After connecting the monitor to the Wi-Fi network, tap the selected network name again. The monitor will display 2 QR codes.
5. Open the Tuya Smart app on your phone and select *Add Device*.
6. In the upper right corner, tap the *Scan* icon.
7. Scan the right QR code (device pairing QR code) displayed on the monitor.
8. Wait for the devices to pair – this may take a few minutes.
9. Once paired, you can assign a custom name to the video doorphone and then test its operation.

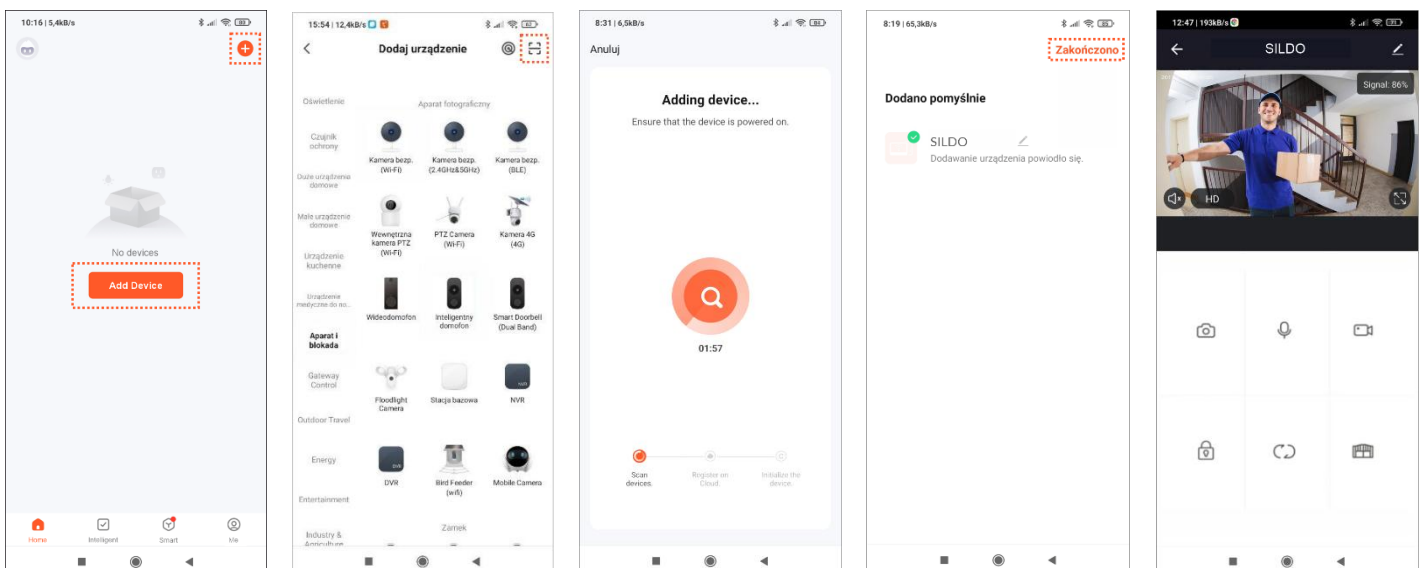

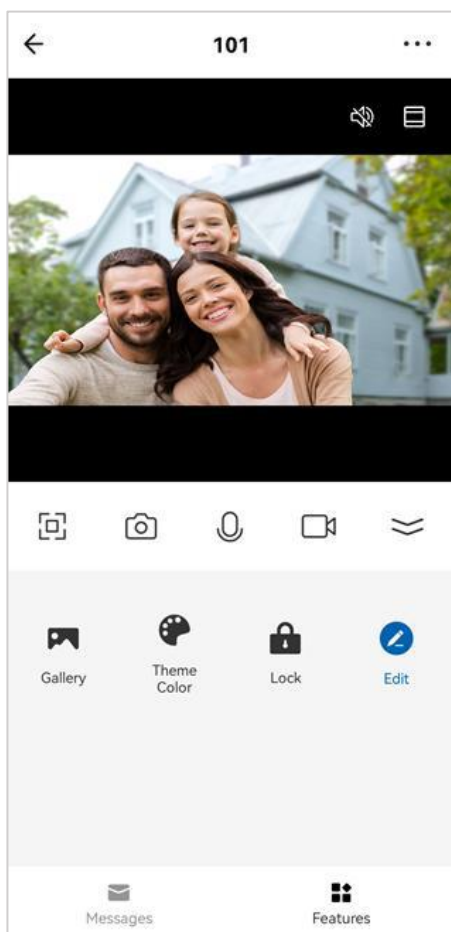

16. APP USAGE

Note: to ensure the correct functioning of the application, the user is obliged to update the application in accordance with communications from the application operator.



 Mute.

 Zoom.

 Full screen.

 Save photo.

 Talk.

 Save video.

 Expand additional options.

 Saved photos gallery.

 Light mode / dark mode.

 Open the wicket/gate.

 Edit.

ACCESS

Creating a family

Select the *Me* tab in the bottom menu of the application, then go to *Home Management*. Enter a family name (e.g., Smith). Select *Add Members*. The application will display options for sharing the invitation code (e.g., via text message). Invited users can add their device by entering the invitation code in *Home Management* > *Join Home* after installing the application.

All family members can manage the device through the application. Only the family owner and administrators can manage (add/remove) family members.

Sharing access

Open the preview from the outdoor unit and then click the settings icon. Find the *Device Sharing* tab and click *Add Sharing*. Add the user and complete the process. Users added in this way cannot open the wicket or gate.

17. RFID CARDS

The kit includes two Master Cards (yellow Add Master Card and red Delete Master Card) and five blue user cards. All included cards are factory-paired with the system. Additional cards can be added – the maximum number of users is 24.

Adding a user

1. Hold the Add Master Card close to the card reader. The panel will emit one short beep.
2. Hold the new user card close to the reader. The panel will emit two short beeps to confirm.
3. Present additional user cards one by one to register them.
4. After 20 seconds of inactivity, the device will return to normal operating mode.

Deleting all users

1. Hold the Delete Master Card close to the card reader.
2. One long beep indicates that all registered users have been deleted from the device memory.
3. After the signal ends, the outdoor unit will return to normal operating mode. The Add Master Card can be used to add new users.

18. TROUBLESHOOTING

1. No audio and no video.

- a) no power supply voltage,
- b) damaged or incorrectly connected cable – check the installation according to technical requirements,
- c) check whether the installation is exposed to water, moisture, etc.,
- d) check whether the camera lens is obstructed by any object preventing proper view.

2. No video, audio is working properly.

- a) check whether all connections are made correctly according to technical requirements,
- b) check whether the camera lens is obstructed by any object preventing proper view.

3. No audio during conversation.

- a) ensure that the volume level on the monitor is not set to the lowest value,
- b) ensure that there are no objects near the device that may cause signal interference,
- c) check whether all connections are made correctly according to technical requirements.

4. No connection from the outdoor unit after pressing the call button.

- a) check whether all connections are made correctly according to technical requirements.

5. The electric strike does not open every time.

- a) check the independent operation of the electric strike by connecting it to the required voltage,
- b) check whether the parameters of the electric strike comply with the instruction manual.

6. The caller cannot be heard after answering the call.

- a) press the  button to enable two-way intercom,
- b) check whether all connections are made correctly according to technical requirements.

7. The caller can be heard after answering the call, but cannot be responded to.

- a) press the  button to enable two-way intercom,
- b) check whether all connections are made correctly according to technical requirements.

19. CLEANING AND MAINTENANCE

Use a soft, dry or slightly damp cloth to clean the housings of the monitor and the outdoor unit. In case of heavier soiling, a small amount of mild cleaning agent may be used, provided it does not contain alcohol or abrasive substances. Clean the camera lens with particular care, using a dry microfiber cloth or accessories intended for cleaning optical components. Do not use solvents, petrol, alcohol, aerosols, or pressurized cleaning agents, as they may damage the surface or electronic components. Regularly check the condition of the power and signal cables and ensure that they are properly connected. Make sure that the monitor's ventilation openings are not blocked or clogged with dust, as this may lead to overheating. For the outdoor unit, periodically check the condition of the seals and the tightness of the housing, especially after heavy rainfall or during winter conditions.

20. AFTER-SALES SERVICE

If, despite the care we have taken in designing and manufacturing your product, it is not working properly, please contact our technicians in the after-sales service team:

Retail Customer Advisor

Phone: +48 (32) 43 43 110 int. 109,

e-mail: techniczny@orno.pl,

Monday to Friday from 8:00 a.m. to 5:00 p.m..

21. SAFETY-RELATED COMMUNICATION CHANNELS

All complaints and information related to the safety of the product should be reported to the manufacturer via the website: www.virone.pl.

22. ADDITIONAL INFORMATION

In view of the fact that the technical data are subject to continuous modifications, the manufacturer reserves a right to make changes to the product characteristics and to introduce different constructional solutions without deterioration of the product parameters or functional quality. Additional information about VIRONE products is available at www.virone.pl. Orno-Logistic Sp. z o.o. holds no responsibility for the results of non-compliance with the provisions of the present Manual. Orno Logistic Sp. z o.o. reserves the right to make changes to the Manual - the latest version of the Manual can be downloaded from support.virone.pl. Any translation/interpretation rights and copyright in relation to this Manual are reserved.

Responsible entity:

 ORNO-LOGISTIC Sp. z o.o.

ul. Rolników 437, 44-141 Gliwice, Poland

tel. (+48) 32 43 43 110, www.virone.pl

Simplified declaration of conformity

Orno-Logistic Sp. z o.o. declares that the type of radio device VDP-78 Video doorphone set Avoni is compliant with the Directive 2014/53/EU. The full text of the EU declaration of conformity is available at the following web address: www.virone.pl.